



Tray specifications

- 1 Trays must not be too much boxed in



- 2 Trays must have at least a 3mm space between them.

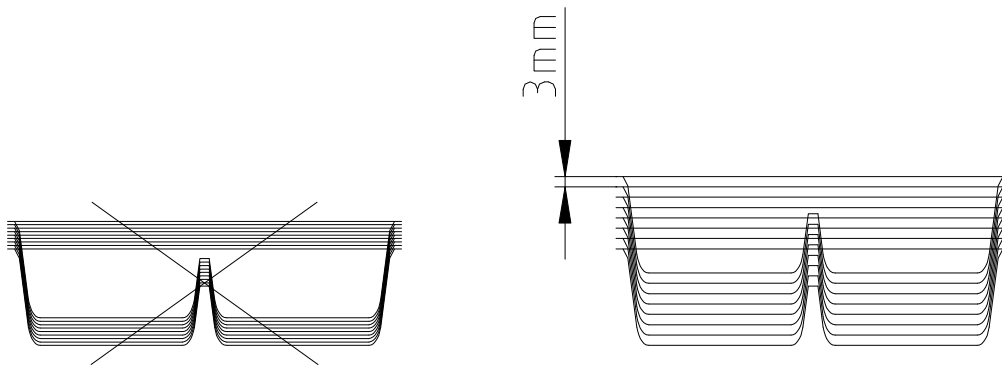

- 3 Cut must be regular and clear (± 0.5 mm).

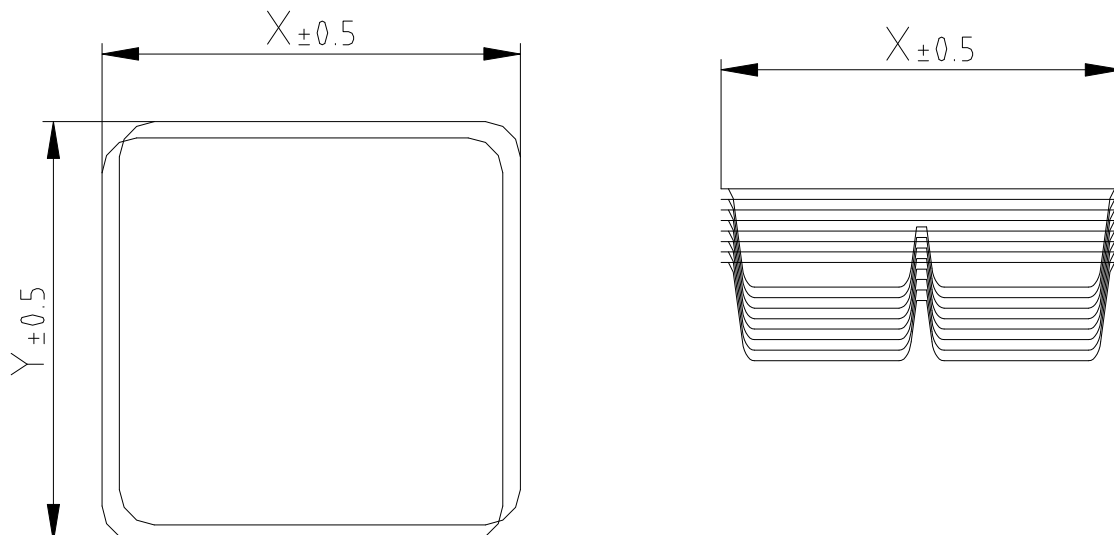



4 Lips must be at least 3mm wide.

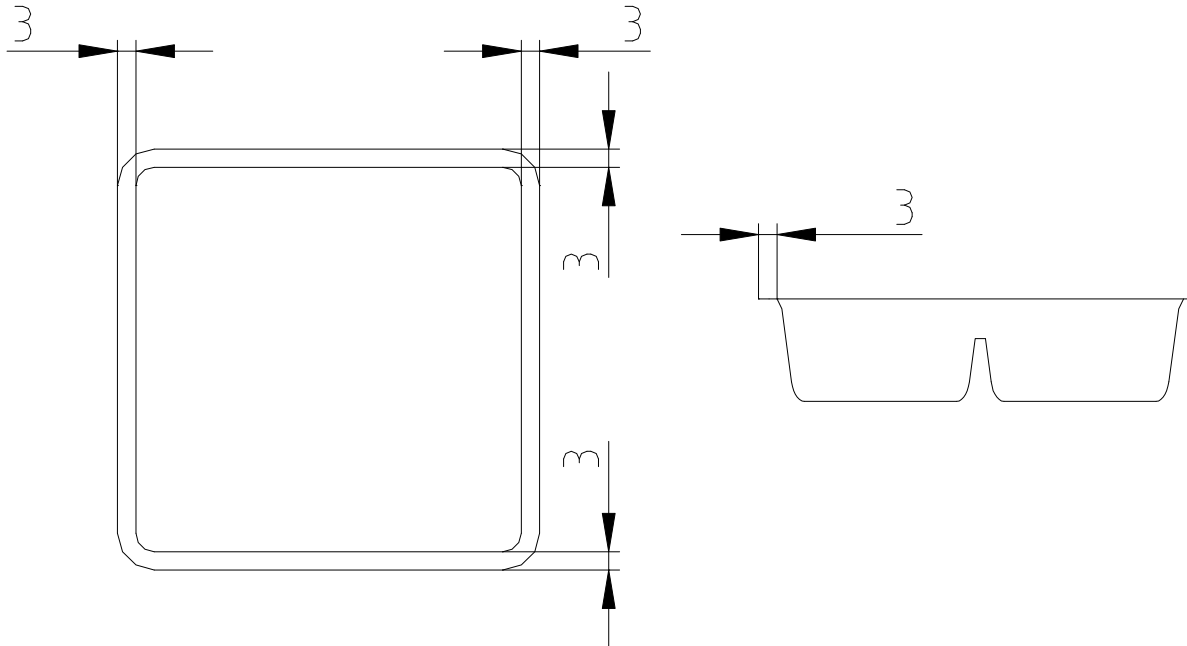

5 Trays must be flat and not deflected.

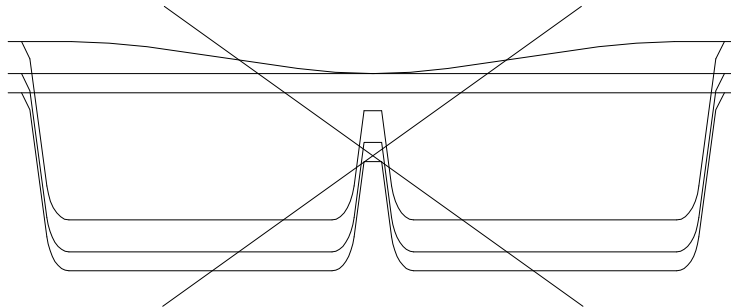

6 Trays must have a proper draft.

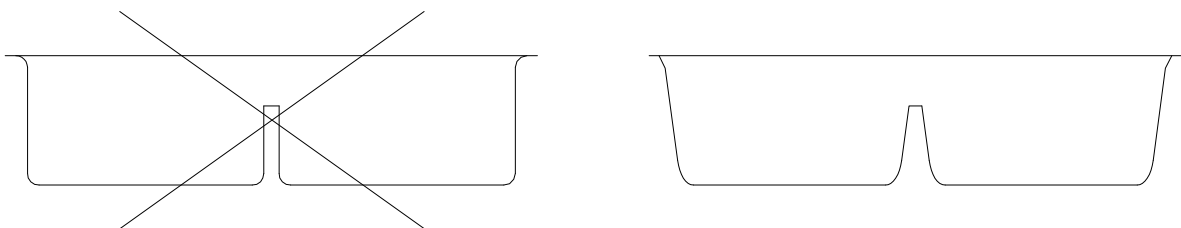



7 Trays must have staggered notches not to be boxed in.

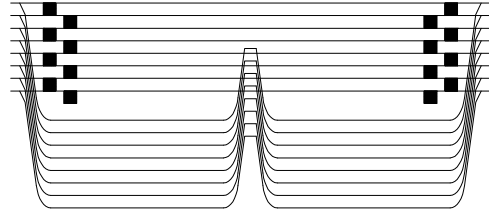
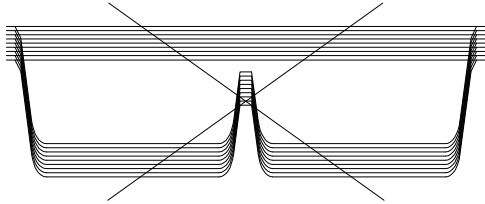

Once the position of notches is confirmed, it must not be modified.

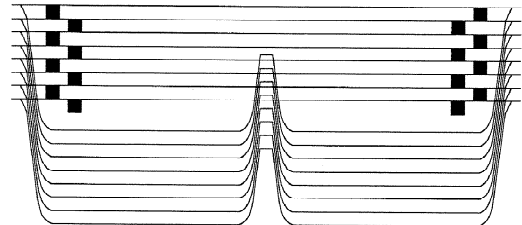
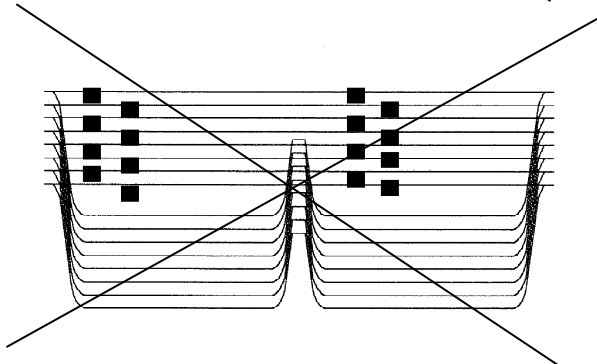
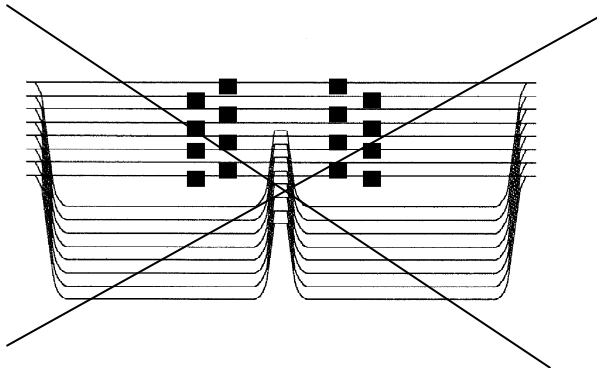

APEX AUTOMATE

PARIS NORD 2
214, Allée des Erables
BP 54298 - Villepinte
95958 ROISSY CDG Cedex
FRANCE



Tel. +33 (0) 1 49 89 09 25
Fax +33 (0) 1 48 63 02 22
Email : apex@apex-automate.com
www.apex-automate.com

- 8 Trays must have a regular thickness to be picked properly by vacuum cups.
They should withstand to a crushing test.

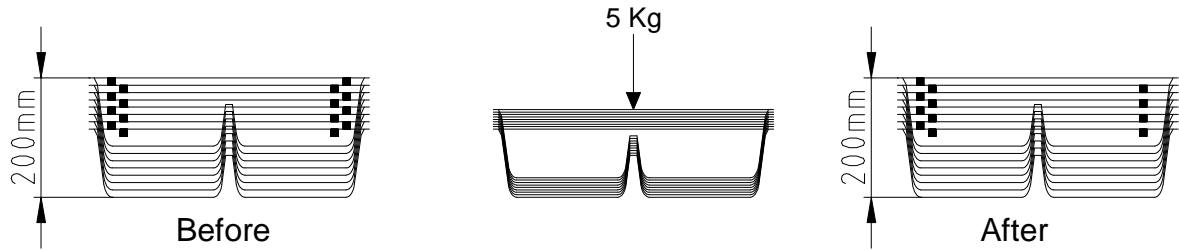

- 9 Position of trays

If trays must be de-nested in a specific way, they should be placed all in the same position in the magazine.

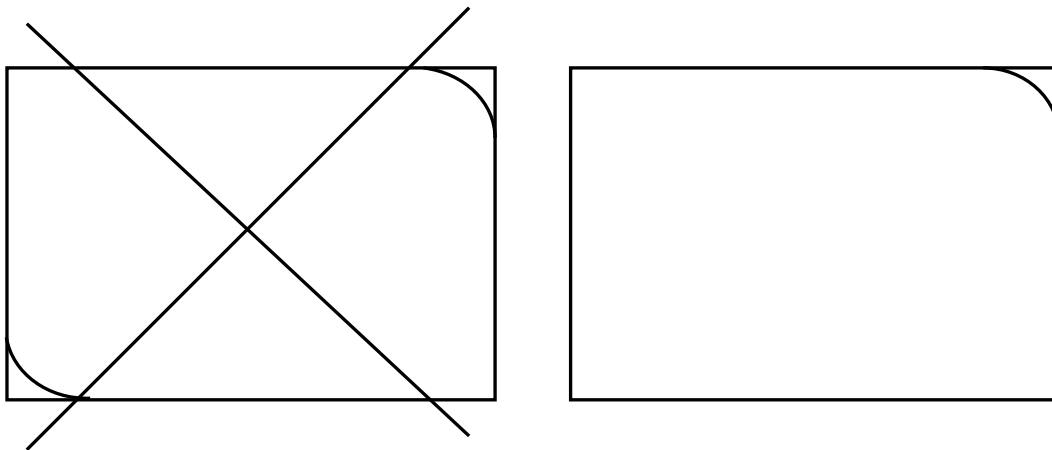

OK

- 10 The following points are also important:

Delivery Storage Loading

We do not give any guarantee if trays are not complying with the above specifications.